

REV.	DATE	DESCRIPTION
NC	01/29/03	INITIAL RELEASE

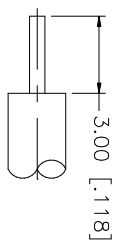

RECOMMENDED
CABLE STRIPPING DIM'S

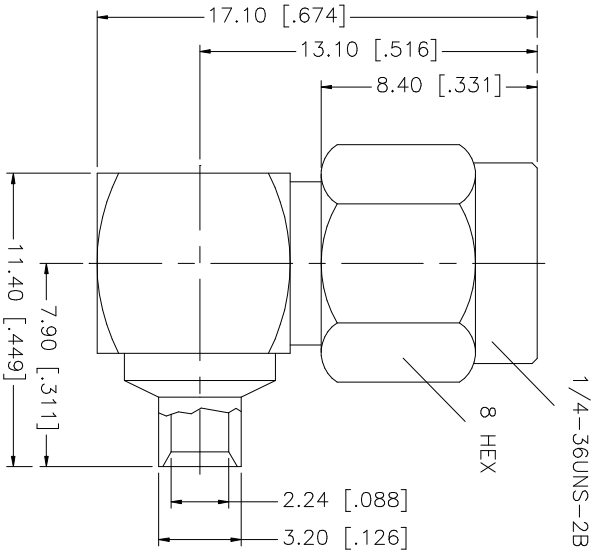
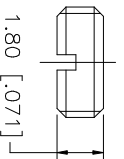

8	COVER	BRASS	GOLD	1	<small>UNLESS OTHERWISE SPECIFIED DIMENSIONS ARE IN MILLIMETERS. DIMENSIONS IN [] ARE IN INCHES AND FOR CUSTOMER REFERENCE ONLY.</small> <small>UNLESS OTHERWISE SPECIFIED TOLERANCES FOR MILLIMETERS ARE:</small> 0.5 - 8mm ± 0.20mm 8 - 30mm ± 0.40mm 30 - 120mm ± 0.50mm <small>UNLESS OTHERWISE SPECIFIED TOLERANCES FOR INCHES ARE:</small> .020 - .315 = ± 0.007" .315 - 1.180 = ± 0.015" 1.180 - 4.724 = ± 0.020" DO NOT SCALE DRAWING	APPROVALS	DATE	Amphenol Connex SMA R/A DIRECT SOLDER PLUG (FOR .085", .086" CABLE)	
7	GASKET	SILICONE	RED	1		DRAWN	G.R.S.		01/29/03
6	RETAINER RING	BER. COPPER	NATURAL	1		CHECKED			
5	CONTACT PIN	BRASS	GOLD	1		ISSUED			
4	INSULATOR	TEFLON	NATURAL	1		SHEET	1 OF 1		
3	BODY	BRASS	GOLD	1		PART NO.	132111		
2	SHELL	BRASS	GOLD	1		DWG. NO.	132111.DWG		
1	DESCRIPTION	MATERIAL	FINISH	QTY		CAD FILE	C:/132/132111.DWG		REV. NC